

GLUCOSINOLATE BIOSYNTHESIS

From methionine

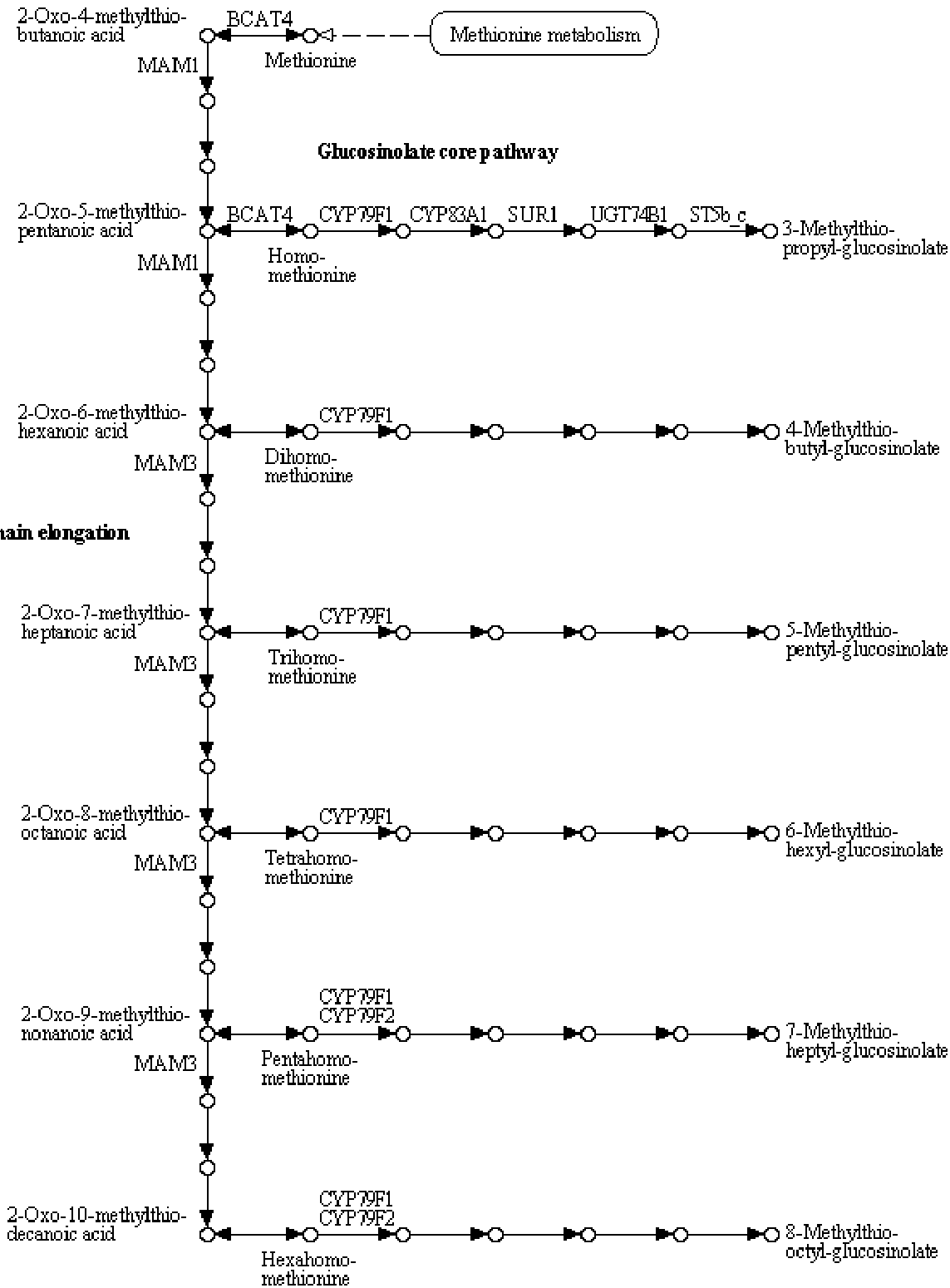

From branched-chain amino acids

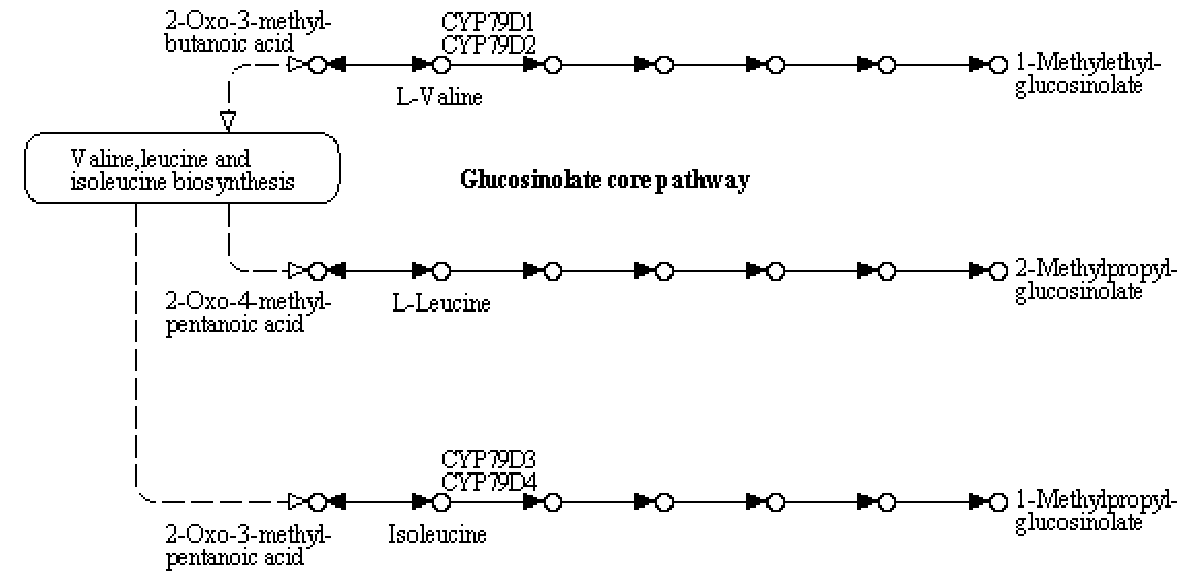

From aromatic amino acid

